

USER'S MANUAL

F08A JUSTICE LEAGUE



MANUAL VERSION · F80A-HAR-F-VA1 0



FEILOLI ELECTRONIC CO., LTD.
<http://www.feiloli.com.tw>

ISSUE DATE : 2016.11.14

CONTENTS

▲ SAFETY NOTICE	1
1 SAFETY NOTICE	1
2 TRANSPORTATION AND MOVING	1
3 POWER NOTICE.....	1
4 ORDER IN POWER ON	1
5 ORDER IN POWER OFF.....	1
● COMPONENT.....	2
1 LIST OF COMPONENTS.....	2
■ ABOUT THE MACHINE	3
1 SPECIFICATION.....	3
2 DIMENSION	3
◆ GAME INTRODUCTION	4
1 HOW TO PLAY	4
2 SYSTEM SETTING.....	4
3 HOW TO CLEAR SCORE, COIN AND TICKET RECORD	5
4 HOW TO TEST THE COIL.....	5
5 FIGURE MECHANISM	6
6 DIP SWITCH SETTING	7
◆ WIRING DIAGRAM.....	10
1 Diagram Of Main Board	10
2 Electronic Meter Diagram	12
3 SYSTEM WIRING DIAGRAM.....	13
◆ TROUBLESHOOTING	14
1 Error Code	14
★ ENCLOSURE	15
1 Warranty	15

▲ SAFETY NOTICE



1 SAFETY NOTICE

- a. Please read carefully with enclosure of “Warranty”.
- b. Please read carefully with enclosure of “Maintenance”.
- c. Please check and maintain the machine regularly, DO NOT use any synthetic detergents to clean the machine.
- d. Places where the ground is sloping, uneven or there is strong vibration.
- e. Avoid direct sunlight machine placed in place in case the internal parts damaged.
- f. Avoid machine in high dust, high humidity, high temperature environment, so as to avoid damage to machine parts.
- g. Machine does not have waterproof, limited to indoor use, do not place water & beverages in the machine.
- h. DO NOT climbing or stand above the machine in any time, to avoid a threat to personal safety.
- i. Any casualties which caused by inappropriate behavior and dangerous acts, the Company shall not be responsible.
- j. This appliance is not for children and persons with reduced physical, sensory or mental capabilities or lack of experience and knowledge.
- k. Do not use this appliance near bathtubs, showers, basins or other vessels containing water.
- l. After using this appliance should be cleaned to avoid the accumulation of grease and other residues.
- m. Children should be supervised to ensure that they do not play with the appliance.
- n. If the supply cord is damaged, it must be replaced by the manufacturer, its service agent or similarly qualified persons in order to avoid a hazard.
- o. Do not use any other subject to hit the machine expect the standard hammer.

2 TRANSPORTATION AND MOVING

- a. Before moving the machine, make sure to unplug it from the mains.
- b. Turn off the power as notice before unplug from the mains, inappropriate handling will cause damage to the machine.

3 POWER NOTICE

- a. Before power connecting, verified the voltage is correct. 110V, 220V or 240V
- b. DO NOT touch the plug with damp hands to avoid electric shock.
- c. When installing the device, should ensure a smooth footing.

4 ORDER IN POWER ON

Plug in and turn on the power.



5 ORDER IN POWER OFF

Turn off the power and unplug

 Wait for 10 seconds to reboot

● COMPONENT

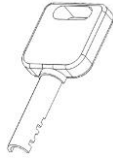
1 LIST OF COMPONENTS

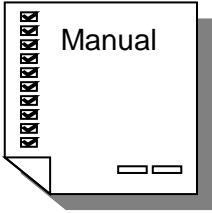
ITEM	DESCRIPTION	PICTURE
a. KEY	QT'Y : 2 REMARK : 2735 x 2	
b. Power line	QT'Y : 1 REMARK : Plug form according area.	
c. Manual	QT'Y : 1 pc REMARK :	

■ ABOUT THE MACHINE

1 SPECIFICATION

a. Voltage & Frequency	Voltage : 100V 、 110V 、 220V 、 240V (Refer to Specification Label) Frequency : 50 / 60HZ
b. Dimension	(W)1122 x (D) 807 x (H)2217 mm
c. User	1 person
d. Environment	Weather Protected Environment
e. Temperature	0°C~40°C
f. Humidity	10%~70%
g. Power Consumption	Maximum : 660W

2 DIMENSION

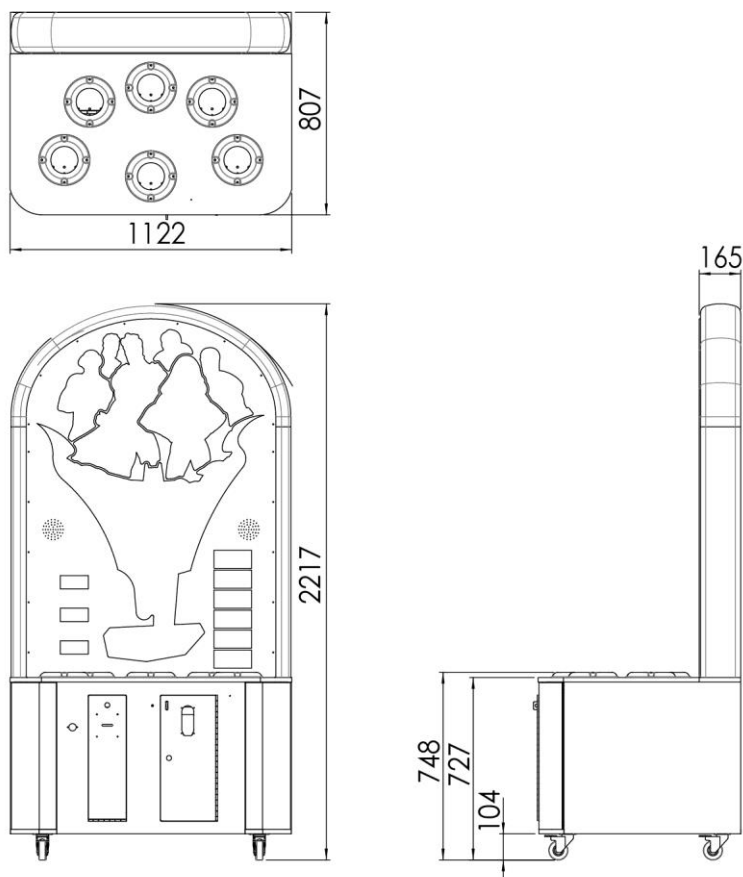

◆ GAME INTRODUCTION

1 HOW TO PLAY

a. Game Instruction :

- (1) Hit rising figures to score
- (2) The game provides 2 stages. Reach setting scores in stage 1 to enter stage 2.
- (3) Game time and score for stage 2 are adjustable by DIPSW.

2 SYSTEM SETTING

➤ Electronic Counter

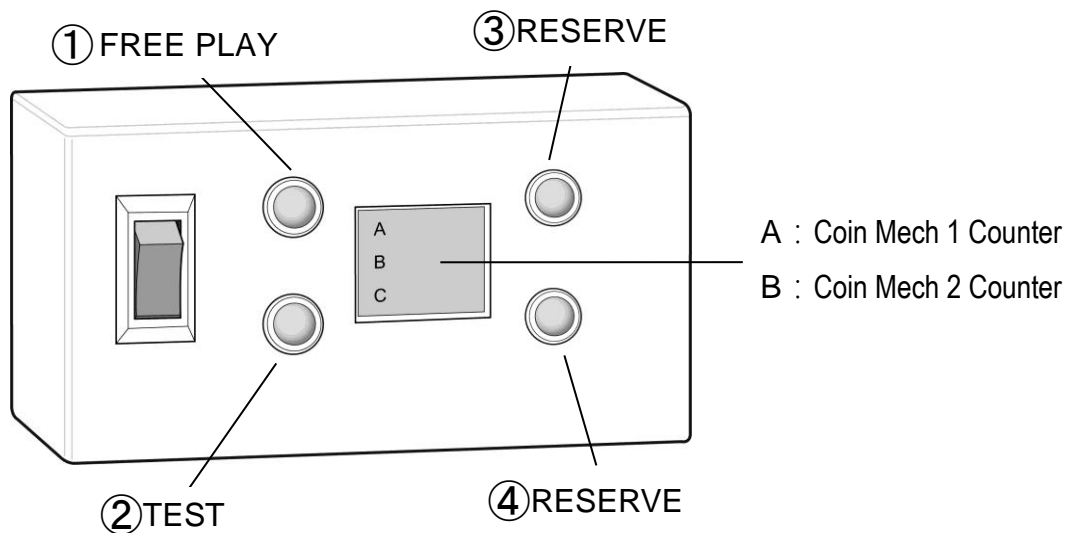

Free play button : Free game will not activate input counters.

Test button : For test of figures and figures' sensors

3 HOW TO CLEAR SCORE, COIN AND TICKET RECORD

- (1) Keep pressing TEST button and turn on the machine. Release the button when it shows "222" on display and it will show "001" for reset item 1.
- (2) Press TEST button to reset and it will alarm once.
- (3) Press FREE PLAY button to enter next item.

Reset items list:

[001] : Score for last game

[002] : Coin memory

[003] : Tickets memory

- (4) Reboot the machine after reset

4 HOW TO TEST THE COIL

In stand-by mode, press TEST button to test coil.

- (1) All coils will be off for initial test. If there is any coil (figure) is rising or its sensor is on, it will alarm correspondent error code. It maybe caused by sensor or coil malfunctioning.
- (2) And then figures will rise in turn for test of all figures and its sensor. If there is any one of figures failed to rise or sensors off, it will also alarm correspondent error code.

5 FIGURE MECHANISM

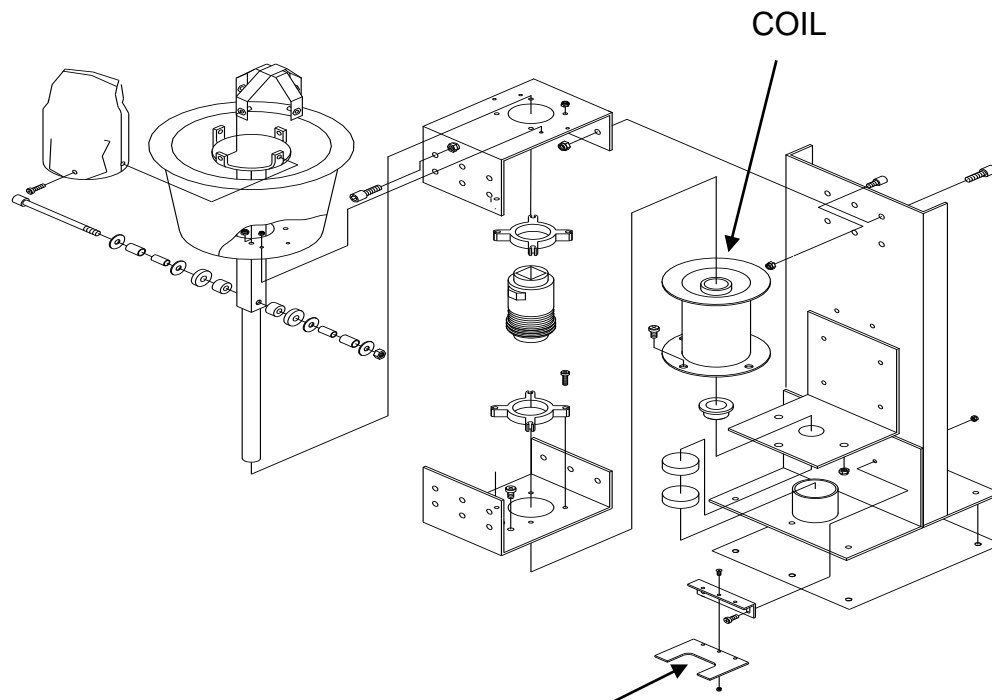

SENSOR : Obstruct->MCU induct the signal in I O

- (1) Press down or pull the doll when game proceeding will be not cause any breakdown.
- (2) Malfunction by 1 or 2 of the doll won't effect others.
- (3) Test progress: Test button on the counter base.
Press "TEST" button to test each doll, please check the "Elimination of Malfunction"
if there has any breakdown.
- (4) The Coil is equipped with temperature protection to prevent overheated.

6 DIP SWITCH SETTING

DIP SW 1

1=ON 0=OFF

FUNCTION / DIP		1	2	3	4	5	6	7	8
COIN 1	1 COIN 1 CREDIT	0	0						
	1 COIN 2 CREDITS	1	0						
	1 COIN 4 CREDITS	0	1						
	1 COIN 5 CREDITS	1	1						
COIN 2	1 COIN 1 CREDIT			0	0				
	1 COIN 2 CREDITS			1	0				
	1 COIN 4 CREDITS			0	1				
	1 COIN 5 CREDITS			1	1				
CREDIT(S) PER PLAY	1 CREDIT					0	0		
	2 CREDITS					1	0		
	3 CREDITS					0	1		
	4 CREDITS					1	1		
COIN MEMORY	Y							0	
	N							1	
ATTRACT MUSIC	Y								0
	N								1

REMARK : REBOOT THE MACHINE IF THE DIP SW SETTING CHANGED

DIP SW 2

1=ON 0=OFF

FUNCTION / DIP		1	2	3	4	5	6	7	8
TICKET PAYOUT	5 POINTS 1 TICKET	0	0	0					
	10 POINTS 1 TICKET	1	0	0					
	20 POINTS 1 TICKET	0	1	0					
	30 POINTS 1 TICKET	1	1	0					
	40 POINTS 1 TICKET	0	0	1					
	50 POINTS 1 TICKET	1	0	1					
	60 POINTS 1 TICKET	0	1	1					
	70 POINTS 1 TICKET	1	1	1					
MERCY TICKET	0 TICKET				0				
	1 TICKET				1				
MAXIMUM TICKET PAYOUT	UNLIMITED					0			
	20 TICKETS					1			
TICKET MEMORY	Y							0	
	N							1	
TICKET PAYOUT	N								0
	Y								1

REMARK : REBOOT THE MACHINE IF THE DIP SW SETTING CHANGED

DIP SW 3

1=ON 0=OFF

FUNCTION / DIP		1	2	3	4	5	6	7	8
GAME TIME FOR STAGE 1	30 SECONDS	0	0						
	40 SECONDS	1	0						
	50 SECONDS	0	1						
	60 SECONDS	1	1						
GAME TIME FOR STAGE 2	10 SECONDS			0					
	20 SECONDS			1					
FREE PLAY MODE	N				0				
	Y				1				
PASS SCORE FOR STAGE 1	40					0	0		
	50					1	0		
	60					0	1		
	80					1	1		
LINKING GAME SETTING	SLAVE							0	
	MASTER							1	
AUTO RUN	N								0
	Y								1

REMARK : REBOOT THE MACHINE IF THE DIP SW SETTING CHANGED

◆ WIRING DIAGRAM

1 DIAGRAM OF MAIN BOARD

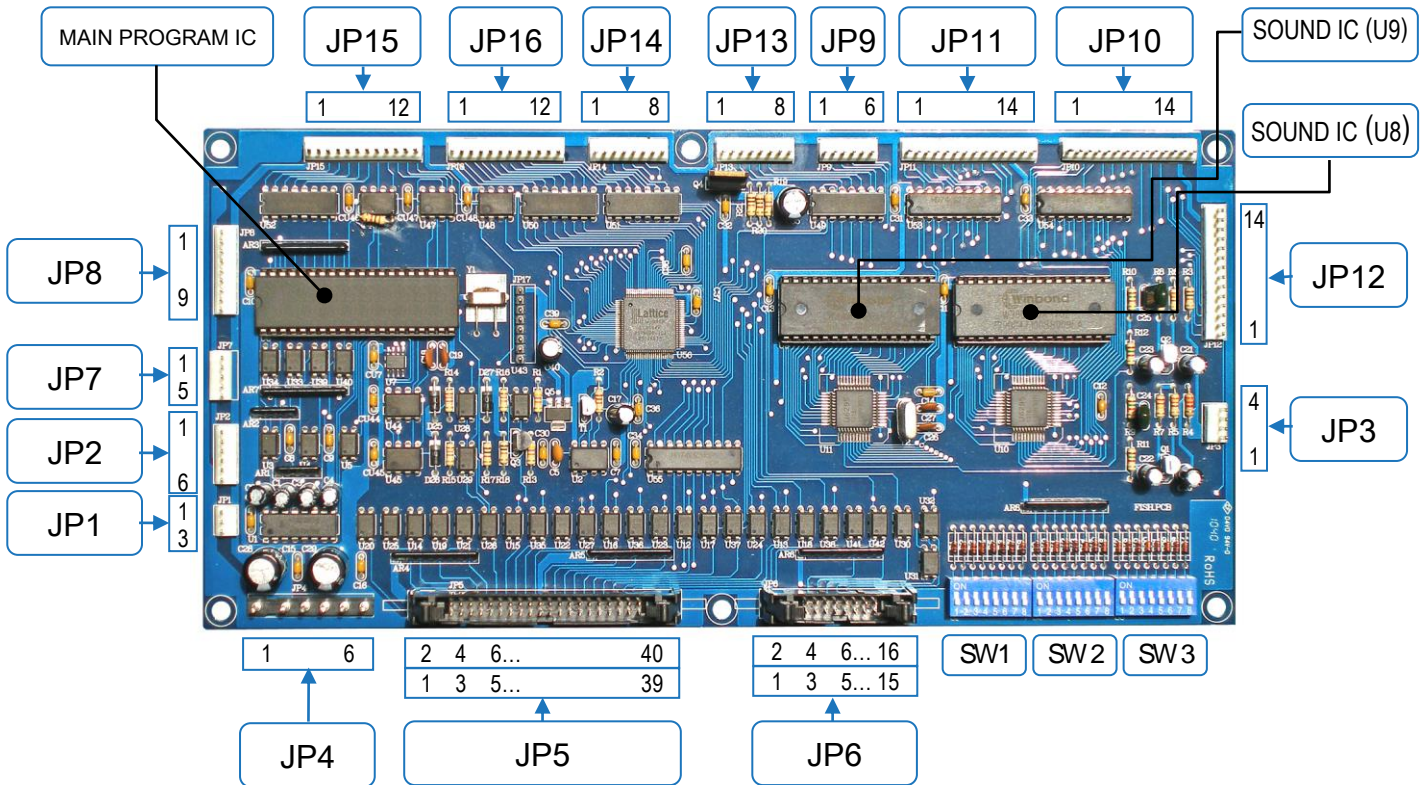

JP1(Linking)	JP2 (Coin Selector)	JP3 (Sound Out Put)	JP4 (Power Input)
1. (Red)TXD 2. (White)RXD 3. (Black)GND	1. (Yellow)Coin Selector V+ 2. (White)Coin Selector Input 3. (Black)GND 4. (Yellow) V+ 5. No Use 6. (Black)Coin Selector GND	1. (White)Out Put 2. No Use 3. GND 4. GND	1. (Yellow)+12V 2. (Yellow).+12V 3. (Black)GND 4. (Black)GND 5. (Red)+5V 6. (Red)+5V
JP5 (Hitting Detector)			
1.(Brown) Figure Sensor 1 3.(Grey) Figure Sensor 6 5.No Use 7.No Use 9.(Orange) Figure Sensor 2 11.No Use 13.No Use 15.No Use 17.(Green) Figure Sensor 3 19.No Use	21.No Use 23.No Use 25.(Blue) Figure Sensor 4 27.No Use 29.No Use 31.No Use 33.(Purple) Figure Sensor 5 35.No Use 37.No Use 39.No Use	2.(Yellow)+12V 4.(Yellow)+12V 6.(Yellow)+12V 8.(Yellow)+12V 10.(Yellow)+12V 12.(Yellow)+12V 14.+12V 16.+12V 18.+12V 20.+12V	22.(Black)GND 24.(Black)GND 26.(Black)GND 28.(Black)GND 30.(Black)GND 32.(Black)GND 34.GND 36.GND 38.GND 40.GND

JP6 (No Use)		JP7 (Ticket Dispenser)	JP8 (In/Out Counter)
1.No Use 3.No Use 5.No Use 7.No Use 9.No Use 11.NC 13.NC 15.+12V	2.GND 4.GND 6.GND 8.GND 10.+12V 12.+12V 14.+12V 16.+12V	1. Ticket Dispenser (Tecway) 2. (Blue)Ticket Detector 3. Ticket Dispenser (Yenox)(White) 4. GND(Black) 5. +12V(Red)	1. (Black)Free Play GND 2. (Brown)Free Play 3. (Black)Test SW GND 4. (Green)Test SW 5. GND 6. (Yellow)+12V 7. (Blue)In Counter1 8. (Purple)In Counter 9. (Grey)Out Counter
JP9(Game Mode)	JP10(Score Display)	JP11 (Time Display / Best Score)	JP12 (Coin Display)
1. +12V(Yellow) 2. (Brown) Single Button Light 3. (Orange) Linking Button Light 4. (Black in Brown) Single Button 5. (Black in Orange) Linking Button 6. GND(Black)	1. (Black)light D0 2. (Brown)light D1 3. (Red)lightD2 4. (Orange)light D3 5. (Yellow)light D4 6. (Green)light D5 7. (Blue)light D6 8. (Black)light D7 9. (Brown)units digit driver 10. (Red)tens digit driver 11. (Orange)hundreds' digit 12. (Yellow)VCC 13. (Green)+12V 14. (Blue)GND	1. (Black)light D0 2. (Brown)light D1 3. (Red)lightD2 4. (Orange)light D3 5. (Yellow)light D4 6. (Green)light D5 7. (Blue)light D6 8. (Black)light D7 9. (Brown)units digit driver 10. (Red)tens digit driver 11. (Orange)hundreds' digit 12. (Yellow)VCC 13. (Green)+12V 14. (Blue)GND	1. (Black)light D0 2. (Brown)light D1 3. (Red)lightD2 4. (Orange)light D3 5. (Yellow)light D4 6. (Green)light D5 7. (Blue)light D6 8. (Black)light D7 9. (Brown)units digit driver 10. (Red)tens digit driver 11. (Orange)hundreds' digit 12. (Yellow)VCC 13. (Green)+12V 14. (Blue)GND
JP13 (Level Light)	JP14 (Head Driver)	JP15 (Cover LED 2)	JP16 (Cover LED 1)
1. (Yellow)+12V 2. (Yellow)+12V 3. (Gray) Level Light 1 4. (Purple) Level Light 2 5. (Blue) Level Light 3 6. (Green) Level Light 4 7. GND 8. GND	1. (Brown) Figure Enable 1 2. (Orange) Figure Enable 2 3. (Green) Figure Enable 3 4. (Blue) Figure Enable 4 5. (Purple) Figure Enable 5 6. (Grey) Figure Enable 6 7. (Yellow)+12V 8. (Yellow)+12V	1. (Yellow)+12V 2. (Yellow)+12V 3. (White in Red)Cover LED Back Right_R 4. (White in Green) Cover LED Back Right_G 5. (White in Blue) Cover LED Back Right_B 6. (White in Red) Cover LED Back Middle_R 7. (White in Green) Cover LED Back Middle_G 8. (White in Blue) Cover LED Back Middle_B 9. (White in Red) Cover LED Back Left_R 10. (White in Green) Cover LED Back Left_G 11. (White in Blue) Cover LED Back Left_B 12. (Gray) Level Light 6	1. (White in Red) Cover LED Front Left_R 2. (White in Green) Cover LED Front Left_G 3. (White in Blue) Cover LED Front Left_B 4. (White in Red) Cover LED Front Middle_R 5. (White in Green) Cover LED Front Middle_G 6. (White in Blue) Cover LED Front Middle_B 7. (White in Red) Cover LED Front Right_R 8. (White in Green) Cover LED Front Right_G 9. (White in Blue) Cover LED Front Right_B 10. (Purple) Level Light 5 11. (Yellow)+12V 12. (Yellow)+12V

2 ELECTRONIC METER DIAGRAM

Button S1 : FREE PLAY Button

Button S2 : TEST Button

Button S3 : NO USE

Button S4 : NO USE

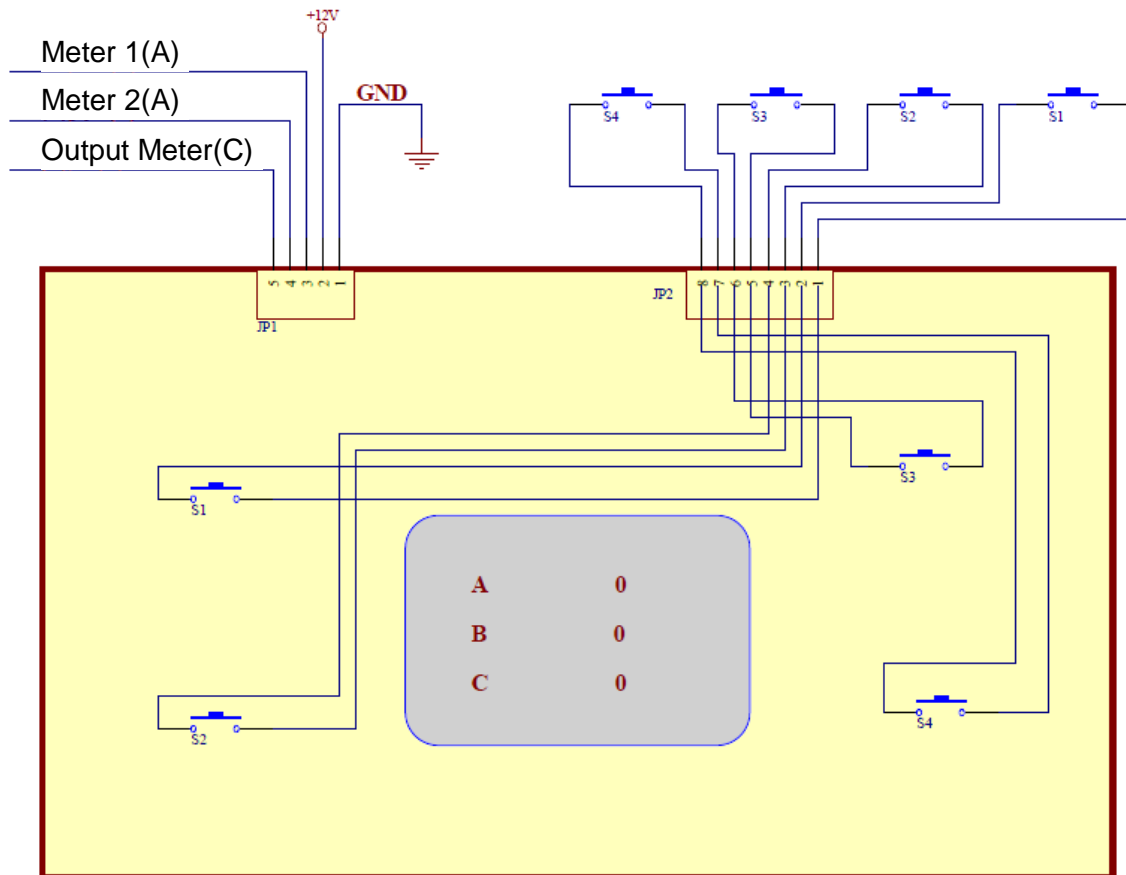

3 SYSTEM WIRING DIAGRAM

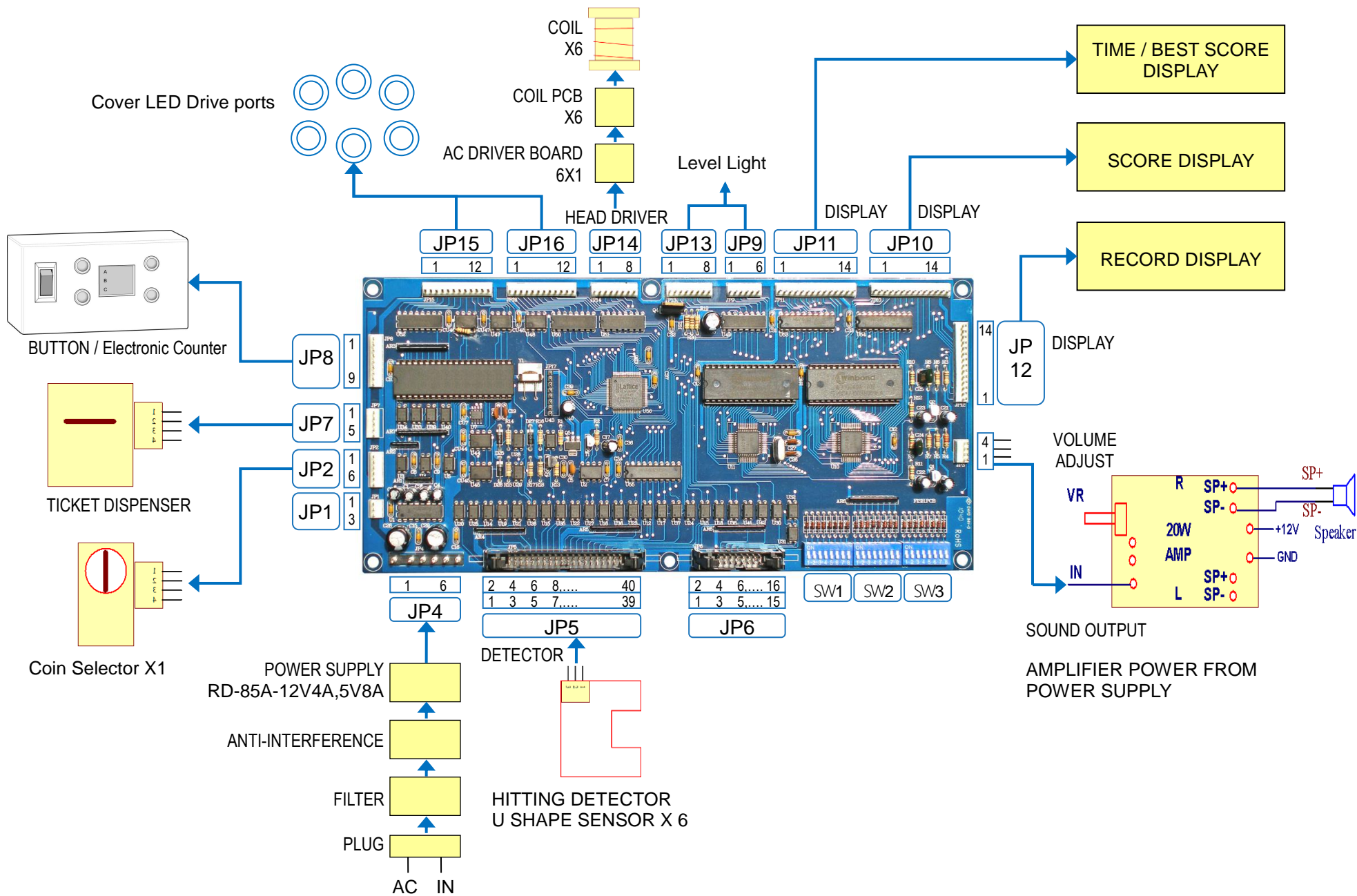

◆ TROUBLESHOOTING

1 ERROR CODE

NO.	ERROR ITEM	SOLUTION
01	Coin Meter 1	(1)Check wire. (2)Replace the Meter.
02	Coin Meter 2	(1)Check wire. (2)Replace the Meter.
03	Ticket Meter	(1)Check wire. (2)Replace the Meter.
04	Coin Selector 1	(1)Check wire. (2)Replace the selector.
05	Coin Selector 2	(1)Check wire. (2)Replace the selector.
06	Memory Card	Replace PCB.
07	Ticket Machine	Check and replenish the token.
08	Linking Game Setting Problem	Set one machine for Master and another for Slave in Linking Game Setting.
11	Coil Set No.1 Error	(1)Check set No.1 and sensor. (2)Replace the sensor.
12	Coil Set No.2 Error	(1)Check set No.2 and sensor. (2)Replace the sensor.
13	Coil Set No.3 Error	(1)Check set No.3 and sensor. (2)Replace the sensor.
14	Coil Set No.4 Error	(1)Check set No.4 and sensor. (2)Replace the sensor.
15	Coil Set No.5 Error	(1)Check set No.5 and sensor. (2)Replace the sensor.
16	Coil Set No.6 Error	(1)Check set No.6 and sensor. (2)Replace the sensor.
21	Structure1 UP SPEED Unusual	(1)check function of structure1 (2)check coil over heat or aging
22	Structure2 UP SPEED Unusual	(1)check function of structure2 (2)check coil over heat or aging
23	Structure3 UP SPEED Unusual	(1)check function of structure3 (2)check coil over heat or aging
24	Structure4 UP SPEED Unusual	(1)check function of structure4 (2)check coil over heat or aging
25	Structure5 UP SPEED Unusual	(1)check function of structure5 (2)check coil over heat or aging
26	Structure6 UP SPEED Unusual	(1)check function of structure6 (2)check coil over heat or aging

★ ENCLOSURE

1 WARRANTY

- a. Please be prepared to provide the following information for place a warranty request :
- (1) The Machine type or product number.
 - (2) Serial Number of Game or Commercial Invoice of Sale.
 - (3) A Detailed Description of the Equipment Fault Symptoms.
- b. All product of Feiloli is warranted as follows :
- (1) Main PCB and Computer: 12 Months since produce finished.
 - (2) Major Mechanism and Kit: 12 Months since produce finished.
 - (3) All other components: 180 days since produce finished.
(i.e. ticket dispenser, coin selector, bill acceptor, printer, LCD, hopper, transformer, card dispenser, and etc.)
 - (4) All repaired items: 90 days since produce finished.
(i.e. Light, hammer, fan, motor, figure, power supply, transmission belt, and etc.)
- c. Please note :
- (1) Major Mechanism and Kit request to return for repair or replacement.
 - (2) Damage through transportation will be cover by Feiloli after issue has been confirmed.
 - (3) The warranty of replacement will be warranted as same as machines or no longer than 90 days since replaced.
 - (4) The copy of warranty is not transferable and applies only to first purchaser.
 - (5) These statements do not contain any warranty due to improper installation, accidents, natural disasters, abuse, misuse, inadequate or excessive volts power supply, improper operation, poor environmental conditions and any unauthorized disassembly, repair, or product damage caused by the changes.
 - (6) These warranty statement does not apply to warranty sticker has been to modify, alter or remove the tear of the product.
The product with packaging damaged, incomplete, second-hand resale or any violation of national resale product.
Data criteria of warranty has been advice as warranty sticker.
 - (7) Warranty does not include copies of third-party, or the connected devices.
Any warranty requirements, the force's responsibility of Feiloli is only to replace the products to consumers. The cost of repair and shipping required by the purchaser.

